

Nº	CODE	CV
23	MT086100	1,5 CV
23	MT086105	2 CV / 3 CV
24	MT021036	1,5 CV
24	MT021045-V	2 CV / 3 CV
24	MT021050	4,5 CV
25	MT076035	2 CV / 3 CV (4 Unit)
26	MT091015	1,5 CV / 3 CV 1-PH
26	MT091030	2 CV 1-PH
27	MT088020	1,5CV / 2CV / 3CV 1-PH
27	MT088010	1,5CV / 2CV / 3CV 3-PH
28	MT076015	1,5CV / 2CV / 3CV 1-PH
29	MT081025	1,5CV / 2CV / 3CV 3-PH
29	MT081020	1,5CV / 2CV / 3CV 3-PH
30	MT076005	
31	MT076000	
32	HD021120	(2 Unit)
33	HD076015	(2 Unit)
34	HD076020	(2 Unit)
35	MT999070	1,5 CV 1-PH
35	MT999075	1,5 CV 3-PH
35	MT999080	2 CV 1-PH
35	MT999085	2 CV 3-PH
35	MT999090	3 CV 1-PH
35	MT999095	3 CV 3-PH
35	MT106115	4,5 CV 3-PH

Nº	CODE	CV
16	MT001020	1,5 CV (2 Unit)
16	MT001025	2 CV / 3 CV (2 Unit)
16	MT001030	4,5 CV (2 Unit)
17	MT006070-V	1,5 CV
17	MT006100-V	2 CV / 3 CV
17	MT006135	4,5 CV
18	MT026005	1,5 CV (2 Unit)
18	MT026010	2 CV / 3 CV (2 Unit)
18	MT026015	4,5 CV (2 Unit)
19	MT096005	1,5 CV
19	MT096010	2 CV / 3 CV
20	MT016055-V	1,5 CV
20	MT016070-V	2 CV / 3 CV
20	MT016095	4,5 CV
21	MT101070	1,5 CV (4 Unit)
21	MT101045	2 CV (4 Unit)
21	MT101050	3 CV (4 Unit)
22	MT086090	1,5 CV
22	MT086095	2 CV / 3 CV
22+23	MT086130	4,5 CV

Nº	CODE	CV
7	HD056005	
8	HD021200	
9	HD061055	
10	HD031050	(8 Unit)
11	HD071015	1,5 CV / 2 CV / 3 CV
11	HD071005	4,5 CV
12	HD066040	
13	HD031010	1,5 CV / 2 CV / 3 CV (4 Unit)
13	HD031036	4,5 CV (4 Unit)
14	HD026025	1,5 CV (4 Unit)
14	HD026065	2CV 3CV 4CV 4,5CV (4 Unit)
15	HD031055	2CV 3CV 4CV 4,5CV (4 Unit)

Nº	CODE	CV
1	HD026040	(8 Unit)
2	HD031005	(8 Unit)
3	HD036000	(2 Unit)
4	HD021100	(2 Unit)
5	HD041165	
6	HD051260	1,5 CV
6	HD051255	2 CV
6	HD051250	3 CV
6	HD051245	4CV
6	HD051240	4,5 CV



INDUSTRIAS MECÁNICAS LAGO S.A.U.
 Pol. Ind. La Rasa - C/ Muntanya, s/n
 17481 Sant Julià de Ramis (Girona) Spain
 Tel. +34 972 17 00 58 - Fax +34 972 17 23 63
 www.imlago.com

EVIDENCE OF CONFORMITY / DÉCLARATION DE CONFORMITÉ / DECLARACIÓN DE CONFORMIDAD / DICHIARAZIONE DI CONFORMITÀ / KONFORMITÄTSEKTLÄRUNG / DECLARAÇÃO DE CONFORMIDADE

- Declares under their own responsibility that all the pumps: **CALA** Manufactured since 20/04/2011, independent of the serial number, are in compliance with:
 - o 2006/42/CE Machine directive safety prescriptions.
 - o 2004/108/CE Electromagnetic compatibility directive.
 - o 2006/95/CE Low voltage Directive.
- Déclare sous sa seule responsabilité que toutes les pompes modèle: **CALA** Fabriquées a partir du 20/04/2011, indépendamment du numéro de série, sont conformes avec:
 - o Directive de sécurité de machines 2006/42/CE.
 - o Directive de compatibilité électromagnétique 2004/108/CE.
 - o Directive d'équipés de basse tension 2006/95/CE.
- Declara bajo su única responsabilidad que todas las bombas del tipo: **CALA** Fabricadas a partir del 20/04/2011, independientemente del número de serie, son conformes con:
 - o Directiva de seguridad de máquinas 2006/42/CE.
 - o Directiva de compatibilidad electromagnética 2004/108/CE.
 - o Directiva de equipos de baja tensión 2006/95/CE.
- Dichiaro sotto la sua diretta responsabilità che tutte le pompe del tipo: **CALA** Prodotte a partire dal 20/04/2011, indipendentemente dal numero di serie, sono conformi a:
 - o Direttiva sulla sicurezza delle macchine 2006/42/CE.
 - o Direttiva sulla compatibilità elettromagnetica 2004/108/CE.
 - o Direttiva apparecchiatura in bassa tensione 2006/95/CE.
- Bescheinigt in alleiniger verantwortung, dass alle Pumpen des typs: **CALA** Ab 20/04/2011, produziert wurden, unabhängig von der seriennummer, konform sind mit:
 - o Richtlinie 2006/42/CE über die sicherheit von maschinen.
 - o Richtlinie 2004/108/CE über elektromagnetische verträglichkeit.
 - o Richtlinie 2006/95/CE über die sicherheit von electrischen betriebsmitteln (Niederspannungsrichtlinie).
- Declara sob sua única responsabilidade que todas as bombas do tipo: **CALA** Produzidas a partir de 20/04/2011, independentemente do número de série, são conformes com:
 - o Directiva de segurança de máquinas 2006/42/CE.
 - o Directiva de compatibilidade electromagnética 2004/108/CE.
 - o Directiva de equipamentos de baixa tenção 2006/95/CE.

Signed the present conformity evidence / Signe la présente déclaration / Firma la presente declaración / Firma la seguente dichiarazione / Unterzeichnet diese erklärung / Assina a presente declaração:

Sant Julià de Ramis, 20/10/2014

Signature / Firma / Unterschrift / Assinatura

CJ021065

Carme Fusté Caixàs, Managing Director of Industrias Mecánicas Lago S.A.U.

COUNTER CURRENT EQUIPMENT OR SPAS PUMP
 POMPES POUR EQUIPEMENT CONTRE COURANT OU SPAS
 BOMBAS PARA EQUIPOS CONTRA CORRIENTE O SPAS
 POMPE PER IMPIANTI CONTROCORRENTE O SPAS
 PUMPEN FÜR GEGENSTROMANLAGE ODER SPAS

SERIE CALA



INSTALLATION AND MAINTENANCE, TECNICAL DATA
 MANUEL D'INSTALLATION ET D'ENTRETIEN, DONNÉES TECHNIQUES
 MANUAL DE INSTALACIÓN Y MANTENIMIENTO, DATOS TÉCNICOS
 MANUALE DI INSTALLAZIONE E MANUTENZIONE, DATI TECNICI
 HINWEISE FÜR EINBAU UND WARTUNG, TECHNISCHE DATEN

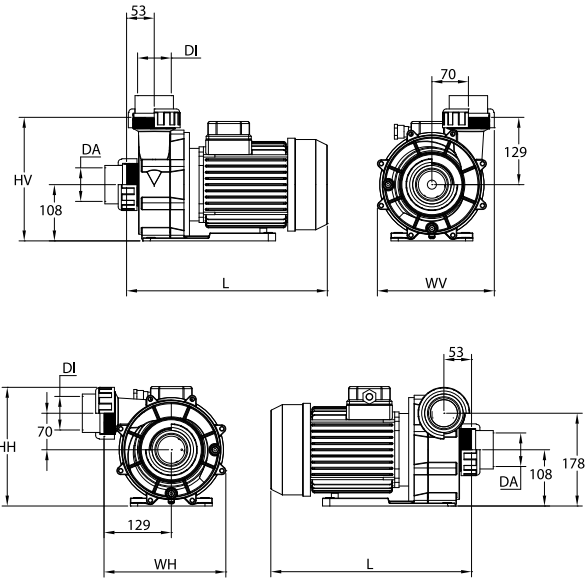

CODIGO CODE	POTENCIA POWER - PUISSANCE		DIMENSIONES - DIMENSIONS mm						PESO BRUTO WEIGHT GROSS POIDS BRUT (Kg.)	VOLUMEN VOLUME m³	
	kW	CV/HP	VERTICAL			HORIZONTAL					
			L	WV	HV	WH	HH	DA			DI
CA150M CA150T	1,1	1,5	350	225	237	235	228	Ø63	Ø63	15,0	0,058
CA200M CA200T	1,5	2,0	365	225	237	235	228	Ø63	Ø63	16,5	0,058
CA300M CA300T	2,2	3,0	385	225	237	235	228	Ø63	Ø63	19,5	0,058
CA450T	2,9	4,5	415	225	237	235	228	Ø63	Ø63	22,5	0,058

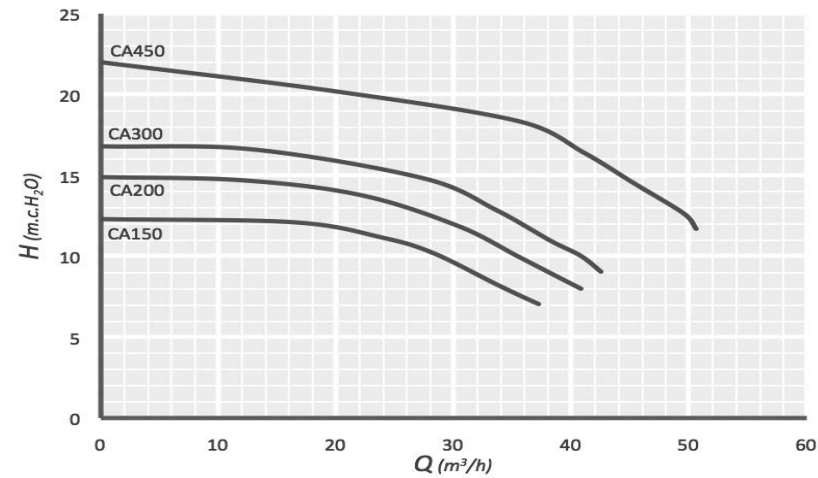

ELECTRICAL CONNECTIONS - BRANCHEMENTS ÉLECTRIQUES
 CONEXIONES ELÉCTRICAS - COLLEGAMENTI ELETTRICI
 ELEKTRISCHE ANSCHLÜSSE - CONEXÕES ELÉTRICAS

SINGLE PHASE MOTORS - MOTEURS MONOPHASÉS - MOTORES MONOFÁSICOS
 MOTORI MONOFASE - EINPHASENMOTOREN - MOTORES MONOFÁSICOS

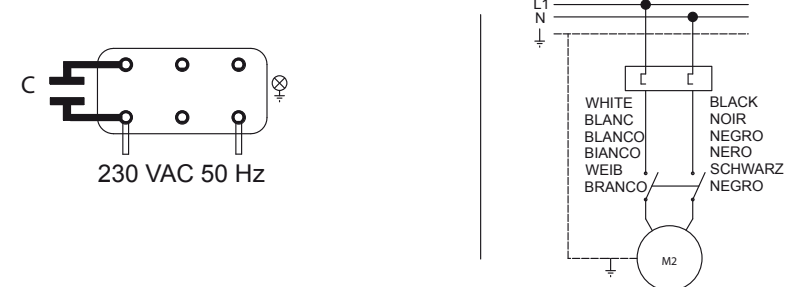

THREE PHASE MOTORS - MOTEURS TRIPHASÉS - MOTORES TRIFÁSICOS
 MOTORI TRIFASE - DREIPHASIGE MOTOREN - MOTORES TRIFÁSICOS

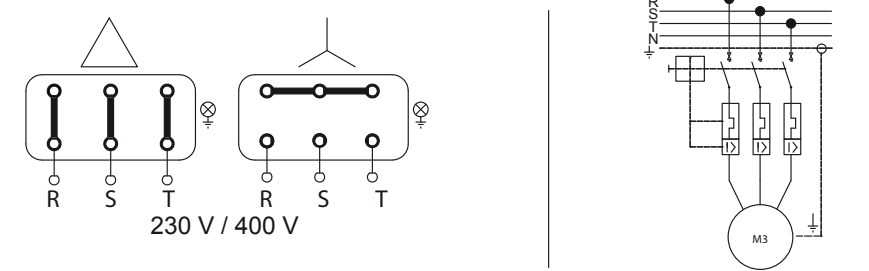

Code	Voltage	Intensity Relay Regulation
CA150M	230 V	7,5 A
CA150T	230/400 V	5,9 / 3,4 A
CA200M	230 V	10 A
CA200T	230/400 V	7 / 4 A
CA300M	230 V	12,1 A
CA300T	230/400 V	7,7 / 4,4 A
CA450T	230/400 V	12,6 / 7,3 A

72 dBA		74 dBA		76 dBA	
CA150M	CA200M	CA300M	CA450T		
CA150T	CA200T	CA300T			

We reserve the right to change all or part of the articles or contents of this document, without prior notice.
 Nous nous réservons le droit de modifier totalement ou en partie les caractéristiques de nos articles ou le contenu de ce document sans préavis.
 Nos reservamos el derecho de cambiar total o parcialmente las características de nuestros artículos o contenido de este documento sin previo aviso.
 Ci riserviamo il diritto di cambiare totalmente o parzialmente le caratteristiche tecniche dei nostri prodotti ed il contenuto di questo documento senza nessun preavviso.
 Wir behalten uns das recht vor, die merkmale unserer produkte und den inhalt dieser beschreibung ohne vorherige ankündigung ganz oder teilweise zu ändern.
 Reservamo-nos no direito de alterar, total ou parcialmente características dos nossos artigos ou conteúdo deste documento sem aviso prévio.

POSITION "V"

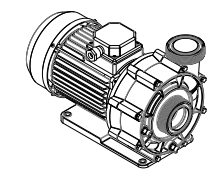

step 1

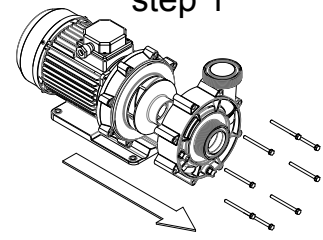

step 2

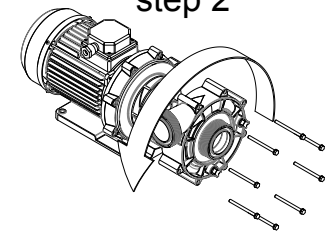

step 3

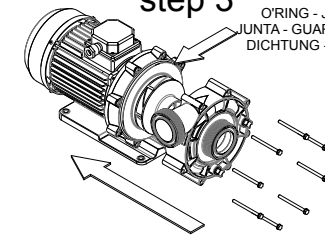

POSITION "H"

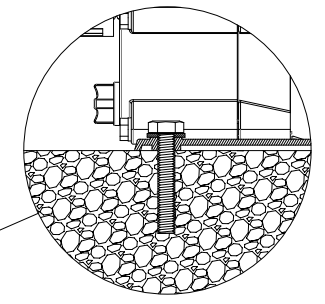
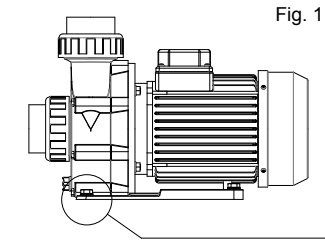
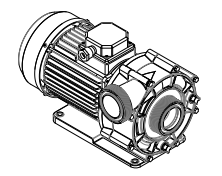

ANCHOR DETAIL
 DETAIL DE L'ANCRAGE
 DETALLE ANCLAJE
 DETTAGLIO ANCORAGGIO
 VERANKERUNG
 DETALHE FIXAÇÃO

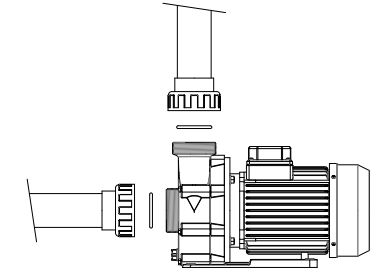

CORRECT - CORRECT - CORRECTO
 CORRETTO RICHTIG - CORRETO

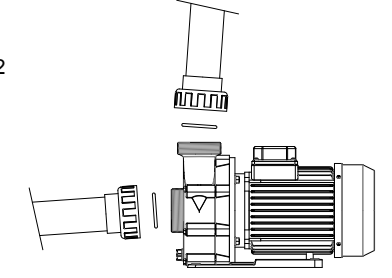

INCORRECT - INCORRECT - INCORRECTO
 NON CORRETTO - UNRICHTIG - INCORRETO

CORRECT - CORRECT - CORRECTO
 CORRETTO RICHTIG - CORRETO

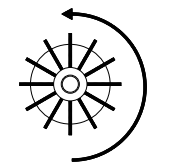
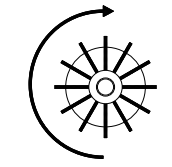
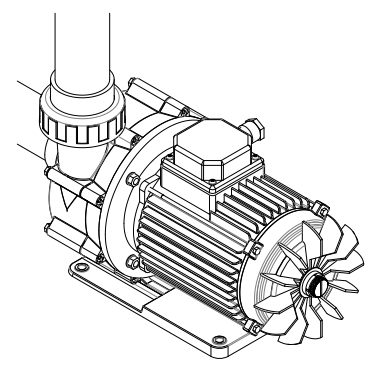

INCORRECT - INCORRECT - INCORRECTO
 NON CORRETTO - UNRICHTIG - INCORRETO

Fig.6